



# Robot Face Plate Spacers

(248) 356-2839

*Spacers used when robot face plates are not thick enough to use an Axis 6 (SD or RDD) bracket*

## Features

- Spaces tool from robot face plate to allow mounting of secondary brackets
- Steel or Aluminum construction
- Two locating points– boss and dowel or two dowels
- Use to mount SD or RDD series Brackets where needed
- Robot Dress assistance readily available
- ‘Value added’ services available



## Usage Examples

Before

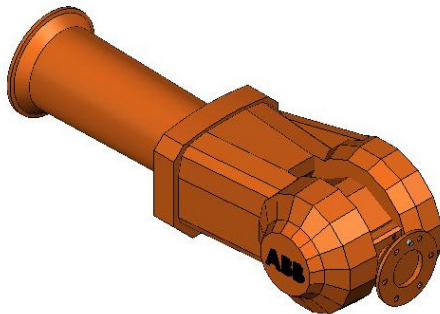

### Robot Wrist

- Not enough room to mount an Axis 6 bracket for dressout purposes

After

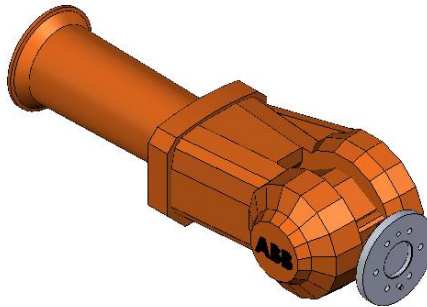

### Robot Wrist w/ Spacer

- Spacer is placed between tool and robot face plate (tool not shown)

In-use

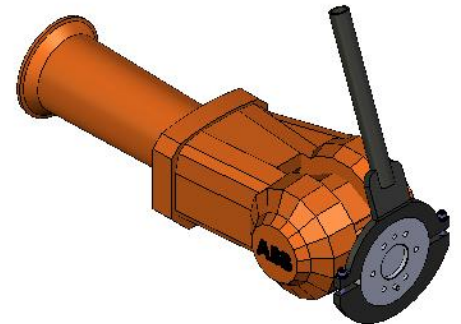

### Robot Wrist w/ Spacer and Axis 6 Bracket

- Spacer allows the Axis 6 bracket to be mounted – assisting in a successful dressout

Notice: The information contained herein is, to the best of our knowledge, true, accurate and reliable. Since procedures and conditions under which these products may be used are beyond our control, no warranty, expressed or implied, is made to their performance.



**Syndevco Inc.**

Sheet: 230818

24205 Telegraph Rd - Southfield MI 48033

Toll Free: (800) 356-2839 Local: (248) 356-2839 Fax: (248) 356-0928

visit us at: [www.syndevco.com](http://www.syndevco.com)



# Robot Face Plate Spacers

## Part Numbering

	Step 1 Define Robot Manufacturer and Model	Step 2 Choose material and finish	Step 3 Choosing Locating Style	Step 4 Define Outside Diameter	Step 5 Define Thickness (after mounting) (in mm)		
FPS-	UUU	V	W	XXX	YYY	Z	
	Robot	Material and Finish	Locating Style	Outside Diameter (in mm)	Thickness (in mm)	Additional Options	
	See a Syndevco Representative for the 3 digit designation	S Steel no finish	A 1 boss 1 dowel	Example		Example	See a Syndevco Representative for further options
		T Steel Oxide-Black	B 2 dowel	160	160 mm	010 10 mm use with RDD	
		A Aluminum no finish		200	200 mm	013 13 mm use with SD	
		B Aluminum Anodized-Black					

SAMPLE PART NUMBER: FPS-F1EA-A200/013

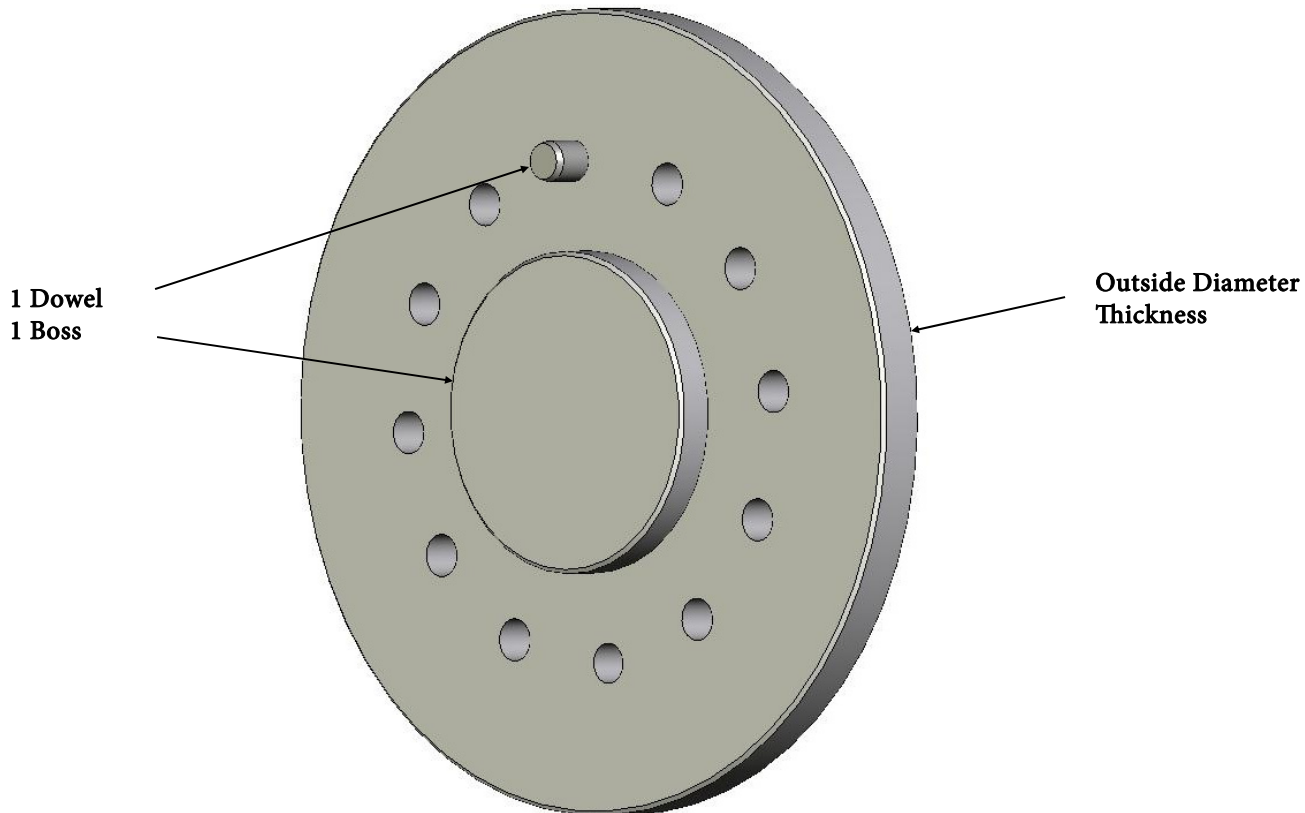

Notice: The information contained herein is, to the best of our knowledge, true, accurate and reliable. Since procedures and conditions under which these products may be used are beyond our control, no warranty, expressed or implied, is made to their performance.



**Syndevco Inc.**

24205 Telegraph Rd - Southfield MI 48033

Toll Free: (800) 356-2839 Local: (248) 356-2839 Fax: (248) 356-0928

visit us at: [www.syndevco.com](http://www.syndevco.com)